

60Hz POWER RATINGS ¹

Voltage AC	Phase	PF	Standby		Prime ²	
			kW	A	kW	A
120/240	1	1	190	792	171	713
120/208	3	0.8	190	659	171	593
277/480	3	0.8	190	286	171	257
347/600	3	0.8	190	229	171	206

¹ All the ratings mentioned are without radiator power consumption. Power may vary based on radiator selection

² Prime power rating is for reference only. Actual power may vary depending on fuel gas quality and operating condition like altitude and ambient temperature

Overview of the SIMMAX series of Industrial Generator Sets

Simson-Maxwell generators are factory-built in facilities that utilize the latest technology, mechanical and electrical component assembly, production, and testing. Each model is the result of computer-aided design and modeling backed up by exhaustive prototype-testing. Our development technology results in a unique range of innovative designs for highly reliable generator sets backed-up by a comprehensive warranty covering all components.

Standard Configuration of Industrial Sets

- Long-life, heavy-duty, 4-cycle, Natural Gas (NG) engines from a world-renowned manufacturer for economy of operation and maximum reliability and durability. Capable of step load and rated load acceptance as per engine manufacturer's specification.
- Cooling: Radiator with belt driven pusher fan or motor driven remote radiator.
- Filtration: Light duty replaceable element air-cleaner.
- Alternator: Single bearing, 4-pole, rotating field, self-excited, self-ventilated, 12-wire re-connectable (6-wire dedicated for 600V), 60Hz brushless alternator with Class H insulation. Automatic voltage regulator (AVR) providing close voltage regulation.
- Arrangement: Open skid with engine and alternator units close coupled together and with seismic anti-vibration isolators mounted between the assembly and a heavy-duty steel base. Lifting lugs are provided as per application.
- Auto Start Control Panel: Digital auto-start microprocessor based control panel with remote start capability.
- Starting System: Electric starter motor, battery cables and belt driven charging alternator.
- CSA certified and meets CSA C282 requirements.

SIMMAX



**POWER
GENERATION**

NATURAL GAS PRODUCT LINE

SGDW190 T6

120/240/208/480/600 Volts
60 Hz/1800 RPM | Standby/Prime

ENGINE SPECIFICATION

Manufacturer	Deutz
Model	TCD2015L08V
Crank shaft speed: rpm	1800
Fuel type	Natural Gas
Aspiration	Turbocharged
Number of cylinder	8
Cylinder arrangement	90° V
Displacement: L	15.872
Bore: mm	132
Stroke: mm	145
Engine standby power: kW	190
Engine prime power: kW	171
Cooling	Water cooled
Governor	Electronic-Woodward F Series
Starting motor voltage	24V DC
Compression ration	12.0:1
Air cleaner type	Light duty air cleaner

EXHAUST SYSTEM

Maximum engine exhaust temperature: °F (°C)	788 (420)
Exhaust gas flow: CFM (m3/hr)	1122.0 (1906.3)
Max. permissible back pressure: PSI (kPa)	0.795 (5.5)

AIR INTAKE & COOLANT^{1 2 3}

Engine combustion air flow: CFM (m3/hr)	695 (1181)
Coolant capacity: Litre	46

HEAT BALANCE

Heat at rejection to coolant: kW	250.0
Heat at rejection radiation from engine: kW	25.2
Heat at rejection to engine exhaust: kW	-

LUBRICATION SYSTEM

Oil pan capacity: Litre	70.0
Oil pan capacity with filter: Litre	72.0
Oil cooler	Integrated full flow
Recommended lubricating oil grade	DEUTZOIL TG-40 LA
Oil consumption at full load: Litre/hr	-
Oil pressure: PSI (kPa)	65.3 (450)

¹ SIMMAX recommends to limit the enclosure air intake velocity to 650ft/minute, and the discharge air velocity to 750 ft/min.

² SIMMAX offers unit mounted radiator or remote radiator solutions based on site requirements.

³ SIMMAX offers options of Air Fuel Ratio Controller and Catalytic converter to ensure engines are emission compliant.

SIMMAX



**POWER
GENERATION**

NATURAL GAS PRODUCT LINE

SGDW190 T6

120/240/208/480/600 Volts
60 Hz/1800 RPM | Standby/Prime

ENGINE ELECTRICAL SYSTEM

Starting motor voltage	24V DC
Battery capacity	2X4D, 24V, 1000A
Cranking Amps minimum	950

FUEL SYSTEM

Recommended fuel	Dry Natural Gas, Min MZ 70, 950BTU/ft ³
Fuel supply line, min. ID: mm	50.0
Fuel supply line max. pressure: kPa	5.22
Fuel supply line min. pressure: kPa	4.7

FUEL CONSUMPTION ¹

	Standby Power		Prime Power
100% Load Standby: BTU/hr	2659709.4	100% Load Prime: BTU/hr	2417917.6
75% Load Standby: BTU/hr	2051500.0	75% Load Prime: BTU/hr	1865000.0
50% Load Standby: BTU/hr	1660508.2	50% Load Prime: BTU/hr	1509552.9
25% Load Standby: BTU/hr	-	25% Load Prime: BTU/hr	-

ALTERNATOR SPECIFICATION

Alternator manufacturer	STAMFORD
Alternator model	HCI434
Voltage	120V - 480V, 600V
Alternator type	Four pole, Rotating field
Excitation system	Brushless, PMG (MX341)
Power factor	0.8
Number of leads	12 leads reconnectable (120V-480V), 6 leads dedicated (600V)
Stator pitch	2/3
Enclosure rating	IP23
Amortisseur windings	Full
Voltage regulation	± 1%
TIF	<50
Line harmonics	5% MAXIMUM
Alternator cooling air flow: CFM (m ³ /hr)	2100 (3568)

STANDARD FEATURES

• Radiator with pusher fan	• Vibration isolators
• Light duty air cleaner	• All rotating components protected with metal guards
• Light-duty engine start batteries with cables	• Operation and maintenance manual
• Emergency stop switch	• CSA certified
• Control Panel (See next page for details)	• Steel base for mounting

¹ Total fuel consumption may vary based on the radiator fan power consumption.

SIMMAX



NATURAL GAS PRODUCT LINE

SGDW190 T6
 120/240/208/480/600 Volts
 60 Hz/1800 RPM | Standby/Prime

Control Systems Standard Features - Generator Digital Control Panel

Standard Configuration of Control Systems

- IntelliLite MRS 16 Controller
- Numerous control systems available, depending on customer requirements
- Automatic or manual start/stop
- Pre-lube function with timers
- Adjustable crank attempts
- Engine warm up/cooling functions
- Digital metering with alarms and shutdowns
- LCD display
- LED indicators
- In-built PLC function
- RS232 (optional RS485 or CAN) communication
- Data logging up to 350 events
- Password protection
- Option available for IntelliGen-NT controller, expansion modules for additional IOs and communication.



Key dimensions and Weights ¹

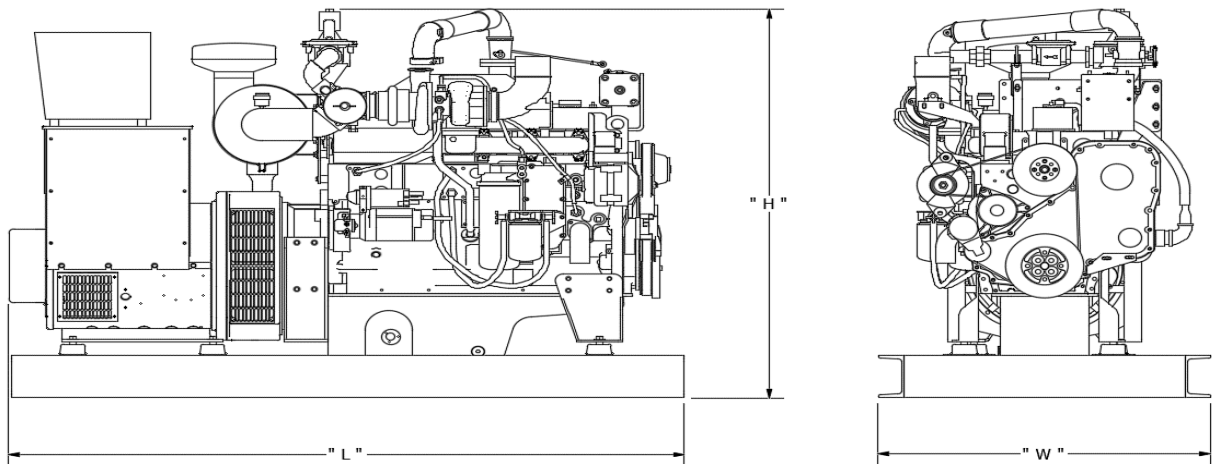

GENERATOR DATA ²			
L = LENGTH - inch (mm)	W = WIDTH - inch (mm)	H = HEIGHT - inch (mm)	DRY WEIGHT - lbs (kg)
100 (2540)	50 (1270)	73 (1854.2)	5312.0 (2409.5)

¹Images are reference only.

²All measurements are approximate and for estimation purposes only. Any deviation can change dimensions. Materials and specifications subject to change without notice.



Simson Maxwell

Calgary | Edmonton | Nanaimo | Port Coquitlam | Prince George | Terrace | Ft. St. John

www.simson-maxwell.com | 800-374-6766

