

60Hz POWER RATINGS

Voltage AC	Phase	PF	Standby		Prime ¹	
			kW	A	kW	A
120/240	1	1	26	108	23	98
120/208	3	0.8	26	90	23	81
277/480	3	0.8	26	39	23	35
347/600	3	0.8	26	31	23	28

¹ Prime power rating is for reference only. Actual power may vary depending on fuel gas quality and operating condition like altitude and ambient temperature

Overview of the SIMMAX series of Industrial Generator Sets

Simson-Maxwell generators are factory-built in facilities that utilize the latest technology, mechanical and electrical component assembly, production, and testing. Each model is the result of computer-aided design and modeling backed up by exhaustive prototype-testing. Our development technology results in a unique range of innovative designs for highly reliable generator sets backed-up by a comprehensive warranty covering all components.

Standard Configuration of Industrial Sets

- Long-life, heavy-duty, 4-cycle, Natural Gas (NG) engines from a world-renowned manufacturer for economy of operation and maximum reliability and durability. Capable of step load and rated load acceptance as per engine manufacturer's specification.
- Cooling: Radiator with belt driven pusher fan or motor driven remote radiator.
- Filtration: Light duty replaceable element air-cleaner.
- Alternator: Single bearing, 4-pole, rotating field, self-excited, self-ventilated, 12-wire re-connectable (6-wire dedicated for 600V), 60Hz brushless alternator with Class H insulation. Automatic voltage regulator (AVR) providing close voltage regulation.
- Arrangement: Open skid with engine and alternator units close coupled together and with seismic anti-vibration isolators mounted between the assembly and a heavy-duty steel base. Lifting lugs are provided as per application.
- Auto Start Control Panel: Digital auto-start microprocessor based control panel with remote start capability.
- Starting System: Electric starter motor, battery cables and belt driven charging alternator.
- CSA certified and meets CSA C282 requirements.

SIMMAX



NATURAL GAS PRODUCT LINE

SGFW25 T6

120/240/208/480/600 Volts
60 Hz/1800 RPM | Standby/Prime

ENGINE SPECIFICATION

Manufacturer	Ford
Model	MSG425
Crank shaft speed: rpm	1800
Fuel type	Natural Gas
Aspiration	Natural
Number of cylinder	4
Cylinder arrangement	Inline
Displacement: L	2.5
Bore: mm	89
Stroke: mm	100
Engine standby power: kW	26
Engine prime power: kW	23.4
Cooling	Water cooled
Governor	Electronic
Starting motor voltage	12V DC
Compression ration	9.7:1
Air cleaner type	Replaceable element type

EXHAUST SYSTEM

Maximum engine exhaust temperature: °F (°C)	1182.2 (639)
Exhaust gas flow: CFM (m3/hr)	206.0 (350)
Max. permissible back pressure: PSI (kPa)	2.948 (20.4)

COOLING SYSTEM^{1 2}

Radiator cooling air flow: CFM (m3/hr)	4070 (6915)	@Max 40°C ambient temperature
Max. restriction of cooling air: in.w.g. (kPa)	0.97 (0.3)	
Engine combustion air flow: CFM (m3/hr)	67.54 (115)	
Total intake air requirement: CFM (m3/hr)	4137.5 (7029.8)	
Coolant capacity: Litre	6.22	

HEAT BALANCE

Heat at rejection to coolant: kW	29.0
Heat at rejection radiation from engine: kW	10.0
Heat at rejection to engine exhaust: kW	20.0

LUBRICATION SYSTEM

Oil pan capacity: Litre	5.7
Oil pan capacity with filter: Litre	6.3
Oil cooler	None
Recommended lubricating oil grade	GF-4, SAE 5W-20
Oil consumption at full load: Litre/hr	-
Oil pressure: PSI (kPa)	34.1 (235)

¹ SIMMAX recommends to limit the enclosure air intake velocity to 650ft/minute, and the discharge air velocity to 750 ft/min.

² SIMMAX offers options of Air Fuel Ratio Controller and Catalytic converter to ensure engines are emission compliant.

SIMMAX



**POWER
GENERATION**

NATURAL GAS PRODUCT LINE

SGFW25 T6

120/240/208/480/600 Volts
60 Hz/1800 RPM | Standby/Prime

ENGINE ELECTRICAL SYSTEM

Starting motor voltage	12V DC
Battery capacity	4D, 12V, 1000A
Cranking Amps minimum	750

FUEL SYSTEM

Recommended fuel	Natural Gas Fumigation 38.7 MJ/m ³ (UK) 39.0 MJ/m ³ (USA)
Fuel supply line, min. ID: mm	25.0
Fuel supply line max. pressure: kPa	3.4838
Fuel supply line min. pressure: kPa	2.7

FUEL CONSUMPTION

	Standby Power		Prime Power
100% Load Standby: BTU/hr	316220.0	100% Load Prime: BTU/hr	268787.0
75% Load Standby: BTU/hr	255457.0	75% Load Prime: BTU/hr	217139.0
50% Load Standby: BTU/hr	195115.0	50% Load Prime: BTU/hr	165848.0
25% Load Standby: BTU/hr	131408.0	25% Load Prime: BTU/hr	111697.0

ALTERNATOR SPECIFICATION

Alternator manufacturer	STAMFORD
Alternator model	PI144
Voltage	120V - 480V, 600V
Alternator type	Four pole, Rotating field
Excitation system	Brushless, Self excited (EBS option available)
Power factor	0.8
Number of leads	12 leads reconnectable (120V-480V), 6 leads dedicated (600V)
Stator pitch	2/3
Insulation	Class H
Windings - temperature rise / Ambient °C	125 / 40
Enclosure rating	IP23
Bearing	Single, Sealed
Amortisseur windings	Full
Voltage regulation	± 1%
TIF	<50
Line harmonics	5% MAXIMUM
Alternator cooling air flow: CFM (m ³ /hr)	340 (578)

STANDARD FEATURES

• Radiator with pusher fan	• Vibration isolators
• Replaceable element type	• All rotating components protected with metal guards
• Light-duty engine start batteries with cables	• Operation and maintenance manual
• Emergency stop switch	• CSA certified
• Control Panel (See next page for details)	• Steel base for mounting

SIMMAX



NATURAL GAS PRODUCT LINE

SGFW25 T6

120/240/208/480/600 Volts
60 Hz/1800 RPM | Standby/Prime

Control Systems Standard Features - Generator Digital Control Panel

Standard Configuration of Control Systems

- IntelliLite MRS 16 Controller
- Numerous control systems available, depending on customer requirements
- Automatic or manual start/stop
- Pre-lube function with timers
- Adjustable crank attempts
- Engine warm up/cooling functions
- Digital metering with alarms and shutdowns
- LCD display
- LED indicators
- In-built PLC function
- RS232 (optional RS485 or CAN) communication
- Data logging up to 350 events
- Password protection
- Option available for IntelliGen-NT controller, expansion modules for additional IOs and communication.



Key dimensions and Weights ¹

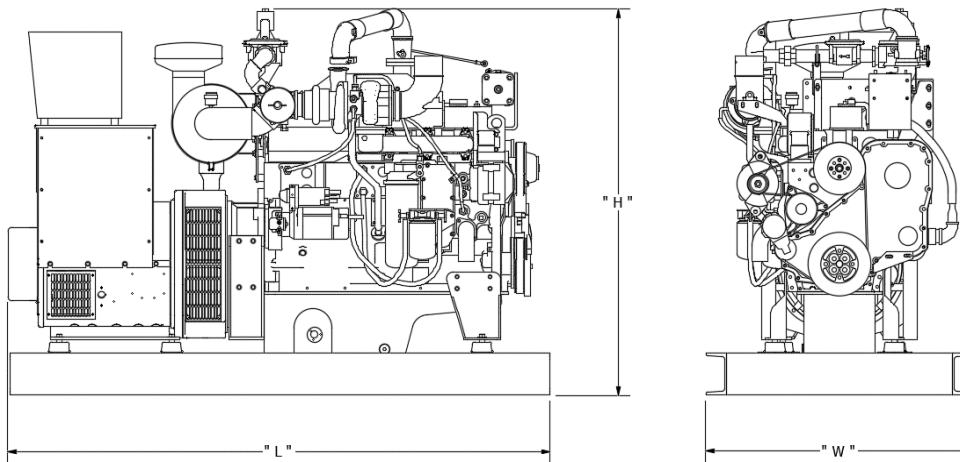

GENERATOR DATA ²

L = LENGTH - inch (mm)	W = WIDTH - inch (mm)	H = HEIGHT - inch (mm)	DRY WEIGHT - lbs (kg)
65 (1651)	30 (762)	46 (1168.4)	1200.0 (544.4)

¹Images are reference only.

²All measurements are approximate and for estimation purposes only. Any deviation can change dimensions. Materials and specifications subject to change without notice.



Simson Maxwell

Calgary | Edmonton | Nanaimo | Port Coquitlam | Prince George | Terrace | Ft. St. John

www.simson-maxwell.com | 800-374-6766

