

### 60Hz POWER RATINGS

Voltage AC	Phase	PF	Standby		Prime*	
			KW	A	Kw	A
277/480	3	0.8	2644	3975	2403	3613
347/600	3	0.8	2644	3180	2403	2890
2402/4160	3	0.8	2644	459	2403	417
12470	3	0.8	2644	153	2403	139

\* Prime power rating for reference only.

## Overview of the SIMMAX series of Industrial Generator Sets

Simson-Maxwell generators are factory-built in facilities that utilize the latest technology, mechanical and electrical component assembly, production, and testing. Each model is the result of computer-aided design and modeling backed up by exhaustive prototype-testing. Our development technology results in a unique range of innovative designs for highly reliable generator sets backed-up by a comprehensive warranty covering all components.

## Standard Configuration of Industrial Sets

- Long-life, heavy-duty, 4-cycle, direct injection diesel engine from a world-renowned manufacturer for economy of operation and maximum reliability and durability. Capable of full-rated load acceptance in one step.
- Cooling: Radiator with belt driven pusher fan.
- Filtration: Heavy duty replaceable element air-cleaner.
- Alternator: Single bearing, 4-pole, rotating field, self-excited, self-ventilated, 12-wire re-connectable (6-wire dedicated for 600V), 60Hz brushless alternator with Class H insulation. Automatic voltage regulator (AVR) providing close voltage regulation.
- Arrangement: Open skid with engine and alternator units close coupled together and with seismic anti-vibration isolators mounted between the assembly and a heavy-duty steel base. Lifting lugs are provided as per application.
- Auto Start Control Panel: Digital auto-start microprocessor based control panel with remote start capability.
- Starting System: Electric starter motor, battery cables, battery and belt driven charging alternator.
- CSA certified and meets CSA C282 requirements.

#### ENGINE SPECIFICATION

Manufacturer	MTU
Model	16V4000G83L
EPA certified	Tier-2
Crank shaft speed: rpm	1800
Fuel type	Diesel
Injection	Direct
Aspiration	Turbocharged
Number of cylinder	20
Cylinder arrangement	90°V
Displacement: L	76.3
Bore: mm	170
Stroke: mm	210
Engine standby power: kW	2740.0
Engine prime power: kW	2490.0
Cooling	Water cooled
Governor	Electronic-ADEC
Starting motor voltage	24V DC
Compression ration	16.4:1
Air cleaner type	Heavy Duty Air Filter

#### EXHAUST SYSTEM

Maximum engine exhaust temperature: °F (°C)	959 ( 515 )
Exhaust gas flow: CFM (m3/hr)	21189.0 ( 36000.4 )
Max. permissible back pressure: PSI (kPA)	1.233 ( 8.5 )

#### COOLING SYSTEM

Radiator cooling air flow: CFM (m3/hr)	86760 ( 147407 )	@Max 40°C ambient temperature
Max. restriction of cooling air: in.w.g. (kPA)	0.483 ( 0.2 )	
Engine combustion air flow: CFM (m3/hr)	7840 ( 13321 )	
Total intake air requirement: CFM (m3/hr)	94600 ( 160726.5 )	
Total coolant capacity: Litre	712	

#### HEAT BALANCE

Heat at rejection to coolant: kW	1865.0
Heat at rejection radiation from engine: kW	209.0
Heat at rejection to engine exhaust: kW	TBA

#### LUBRICATION SYSTEM

Oil pan capacity: Litre	292.0
Oil pan capacity with filter: Litre	300.0
Oil cooler	Integrated full flow
Recommended lubricating oil grade	SAE 10W40
Oil consumption at full load: Litre/hr	6.93
Oil pressure: PSI (kPA)	79.8 ( 550 )

# SIMMAX



**POWER  
GENERATION**

## DIESEL PRODUCT LINE

**SMTW2500 T6-T2**

120/240/208/480/600 Volts

60 Hz/1800 RPM | Standby/Prime

### ENGINE ELECTRICAL SYSTEM

Starting motor voltage	24V DC
Battery capacity	2X8D, 24V, 1500A
Cranking Amps minimum	2800A @-17.8°C

### FUEL SYSTEM

Recommended fuel	Diesel#2
Fuel supply line, min. ID: mm	25.0
Fuel return line min. ID: mm	25.0
Fuel supply line max. restriction: kpa	8.34
Fuel pump type	Engine-driven
Fuel filter	0.005mm Fuel Filter

### FUEL CONSUMPTION

	Standby Power		Prime Power
100% Load Standby: Litre/hr	693.0	100% Load Prime: Litre/hr	630.0
75% Load Standby: Litre/hr	515.0	75% Load Prime: Litre/hr	468.2
50% Load Standby: Litre/hr	356.0	50% Load Prime: Litre/hr	323.6
25% Load Standby: Litre/hr	-	25% Load Prime: Litre/hr	-

### ALTERNATOR SPECIFICATION

Alternator manufacturer	Leroy-Somer
Alternator model	LSA53
Voltage	480V, 600V (Option available)
Alternator type	Four pole, Rotating field
Excitation system	AREP + PMI (PMG option available)
Power factor	0.8
Number of leads	TBA
Stator pitch	2/3
Insulation	Class H
Windings - temperature rise / Ambient °C	125 / 40
Enclosure rating	IP23
Bearing	Single, Sealed
Amortisseur windings	Full
Voltage regulation - no load to full load with DSR AVR	± 0.5%
TIF	<50
Line harmonics	5% MAXIMUM
Alternator cooling air flow: CFM (m3/hr)	6000 ( 10195 )

### STANDARD FEATURES

• Radiator with pusher fan	• Standard fuel filter
• Medium-duty, Heavy Duty Air Filter	• All rotating components protected with metal guards
• Heavy-duty engine start batteries with cables	• Operation and installation literature
• Emergency stop switch	• CSA certified
• Control Panel (See next page for details)	• Steel base for mounting on fuel tank/concrete surface

### OPTIONAL FEATURE: SUB-BASE FUEL TANK \*

Runtime	24 hour	48 hour	72 hour
Tank volume - US gal (L)	4393.7 (16632)	8787.4 (33264)	13181.1 (49896)
Tank size: L x W x H - inch	287 x 92 x 40	315 x 167 x 40	315 x 249 x 40
Tank size: L x W x H - m	7.3 x 2.4 x 1	8 x 4.3 x 1	8 x 6.4 x 1

\* All measurements are approximate and for estimation purposes only. The tank dimensions may vary. For specific sizes, contact sales representative.

Rev: A

Date: 3/29/2018

## Control Systems Standard Features - Generator Digital Control Panel

### Standard Configuration of Control Systems

- Numerous control systems available, depending on customer requirements
- Automatic or manual start/stop
- Pre-lube function with timers
- Adjustable crank attempts
- Engine warm up/cooling functions
- Digital metering with alarms and shutdowns
- LCD display
- LED indicators
- In-built PLC function
- RS232 (optional RS485 or CAN) communication
- Data logging up to 350 events
- Password protection



## Key dimensions and Weights

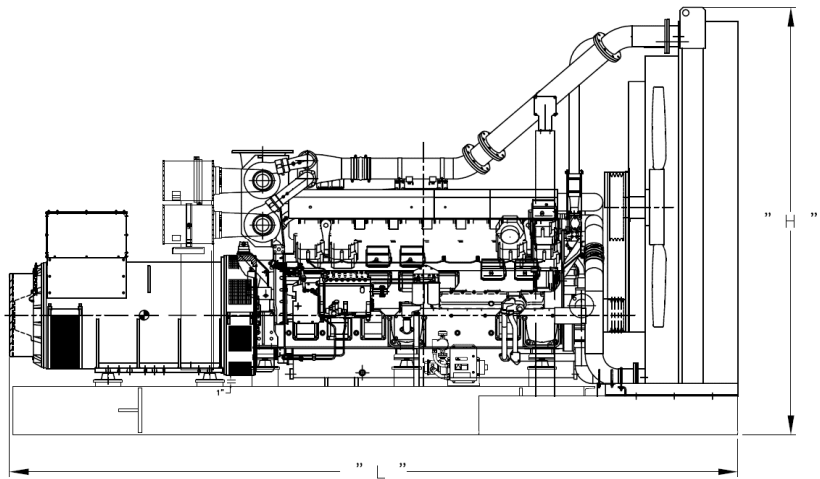
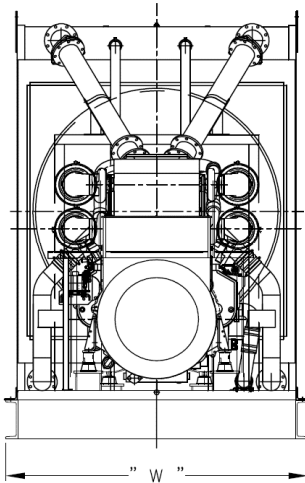

### GENERATOR DATA \*

L = LENGTH - inch (mm)	W = WIDTH - inch (mm)	H = HEIGHT - inch (mm)	DRY WEIGHT - lbs (kg)
282 ( 7162.8 )	91 ( 2311.4 )	131.0 ( 3327.4 )	45206.6 ( 20501.9 )

\* All measurements are approximate and for estimation purposes only. Images are reference only.

Any deviation can change dimensions.

Materials and specifications subject to change without notice.



Simson Maxwell

Calgary | Edmonton | Nanaimo | Port Coquitlam | Prince George | Terrace | Ft. St. John

www.simson-maxwell.com | 800-374-6766

