

60Hz POWER RATINGS

Voltage AC	Phase	PF	Standby		Prime*	
			KW	A	Kw	A
277/480	3	0.8	1295	1947	1172	1763
347/600	3	0.8	1295	1557	1172	1410
2402/4160	3	0.8	1295	225	1172	203

* Prime power rating for reference only.

Overview of the SIMMAX series of Industrial Generator Sets

Simson-Maxwell generators are factory-built in facilities that utilize the latest technology, mechanical and electrical component assembly, production, and testing. Each model is the result of computer-aided design and modeling backed up by exhaustive prototype-testing. Our development technology results in a unique range of innovative designs for highly reliable generator sets backed-up by a comprehensive warranty covering all components.

Standard Configuration of Industrial Sets

- Long-life, heavy-duty, 4-cycle, direct injection diesel engine from a world-renowned manufacturer for economy of operation and maximum reliability and durability. Capable of full-rated load acceptance in one step.
- Cooling: Radiator with belt driven pusher fan.
- Filtration: Heavy duty replaceable element air-cleaner.
- Alternator: Single bearing, 4-pole, rotating field, self-excited, self-ventilated, 12-wire re-connectable (6-wire dedicated for 600V), 60Hz brushless alternator with Class H insulation. Automatic voltage regulator (AVR) providing close voltage regulation.
- Arrangement: Open skid with engine and alternator units close coupled together and with seismic anti-vibration isolators mounted between the assembly and a heavy-duty steel base. Lifting lugs are provided as per application.
- Auto Start Control Panel: Digital auto-start microprocessor based control panel with remote start capability.
- Starting System: Electric starter motor, battery cables, battery and belt driven charging alternator.
- CSA certified and meets CSA C282 requirements.

SIMMAX



POWER GENERATION

DIESEL PRODUCT LINE

SMW1250 T6-T2
120/240/208/480/600 Volts
60 Hz/1800 RPM | Standby/Prime

ENGINE SPECIFICATION

Manufacturer	Mitsubishi
Model	S12RY2PTAW-1
EPA certified	Tier-2
Crank shaft speed: rpm	1800
Fuel type	Diesel
Injection	Direct
Aspiration	Turbocharged
Number of cylinder	12
Cylinder arrangement	60°V
Displacement: L	49.03
Bore: mm	170
Stroke: mm	180
Engine standby power: kW	1353.0
Engine prime power: kW	1225.0
Cooling	Water cooled
Governor	Electronic
Starting motor voltage	24V DC
Compression ration	14.5:1
Air cleaner type	Not Included

EXHAUST SYSTEM

Maximum engine exhaust temperature: °F (°C)	926.6 (497)
Exhaust gas flow: CFM (m3/hr)	12570.0 (21356.6)
Max. permissible back pressure: PSI (kPA)	0.856 (5.9)

COOLING SYSTEM

Radiator cooling air flow: CFM (m3/hr)	62756 (106624)	@Max 40°C ambient temperature
Max. restriction of cooling air: in.w.g. (kPA)	0.483 (0.2)	
Engine combustion air flow: CFM (m3/hr)	4767 (8100)	
Total intake air requirement: CFM (m3/hr)	67523 (114722.4)	
Total coolant capacity: Litre	532	

HEAT BALANCE

Heat at rejection to coolant: kW	1022.0
Heat at rejection radiation from engine: kW	117.0
Heat at rejection to engine exhaust: kW	1387.0

LUBRICATION SYSTEM

Oil pan capacity: Litre	150.0
Oil pan capacity with filter: Litre	180.0
Oil cooler	Water cooled, Multi plate type cooler
Recommended lubricating oil grade	Class CD or CF oil (As per API)
Oil consumption at full load: Litre/hr	3.93
Oil pressure: PSI (kPA)	80.1 (552)

SIMMAX



**POWER
GENERATION**

DIESEL PRODUCT LINE

SMW1250 T6-T2
120/240/208/480/600 Volts
60 Hz/1800 RPM | Standby/Prime

ENGINE ELECTRICAL SYSTEM

Starting motor voltage	24V DC
Battery capacity	2X8D, 24V, 1500A
Cranking Amps minimum	1250 A at -17.8°C

FUEL SYSTEM

Recommended fuel	ASTM D975 No. 1-D, No. 2-D
Fuel supply line, min. ID: mm	25.0
Fuel return line min. ID: mm	25.0
Fuel supply line max. restriction: kpa	10
Fuel pump type	Engine driven gear pump
Fuel filter	Two stage fuel filter

FUEL CONSUMPTION

	Standby Power		Prime Power
100% Load Standby: Litre/hr	393.0	100% Load Prime: Litre/hr	357.3
75% Load Standby: Litre/hr	284.0	75% Load Prime: Litre/hr	258.2
50% Load Standby: Litre/hr	192.0	50% Load Prime: Litre/hr	174.5
25% Load Standby: Litre/hr	110.0	25% Load Prime: Litre/hr	100.0

ALTERNATOR SPECIFICATION

Alternator manufacturer	STAMFORD
Alternator model	PI734
Voltage	480V, 600V
Alternator type	Four pole, Rotating field
Excitation system	Brushless, PMG (MX321)
Power factor	0.8
Number of leads	6 leads dedicated (277V-480V), 6 leads dedicated (600V)
Stator pitch	2/3
Insulation	Class H
Windings - temperature rise / Ambient °C	125 / 40
Enclosure rating	IP23
Bearing	Single, Sealed
Amortisseur windings	Full
Voltage regulation - no load to full load with DSR AVR	± 0.5%
TIF	<50
Line harmonics	5% MAXIMUM
Alternator cooling air flow: CFM (m3/hr)	7300 (12403)

STANDARD FEATURES

• Radiator with pusher fan	• Standard fuel filter
• Medium-duty, Not Included	• All rotating components protected with metal guards
• Heavy-duty engine start batteries with cables	• Operation and installation literature
• Emergency stop switch	• CSA certified
• Control Panel (See next page for details)	• Steel base for mounting on fuel tank/concrete surface

OPTIONAL FEATURE: SUB-BASE FUEL TANK *

Runtime	24 hour	48 hour	72 hour
Tank volume - US gal (L)	2491.7 (9432)	4983.4 (18864)	7475 (28296)
Tank size: L x W x H - inch	186 x 81 x 40	276 x 110 x 40	276 x 163 x 40
Tank size: L x W x H - m	4.8 x 2.1 x 1	7 x 2.8 x 1	7 x 4.2 x 1

* All measurements are approximate and for estimation purposes only. The tank dimensions may vary. For specific sizes, contact sales representative.

Rev: A

Date: 3/29/2018

Control Systems Standard Features - Generator Digital Control Panel

Standard Configuration of Control Systems

- Numerous control systems available, depending on customer requirements
- Automatic or manual start/stop
- Pre-lube function with timers
- Adjustable crank attempts
- Engine warm up/cooling functions
- Digital metering with alarms and shutdowns
- LCD display
- LED indicators
- In-built PLC function
- RS232 (optional RS485 or CAN) communication
- Data logging up to 350 events
- Password protection



Key dimensions and Weights

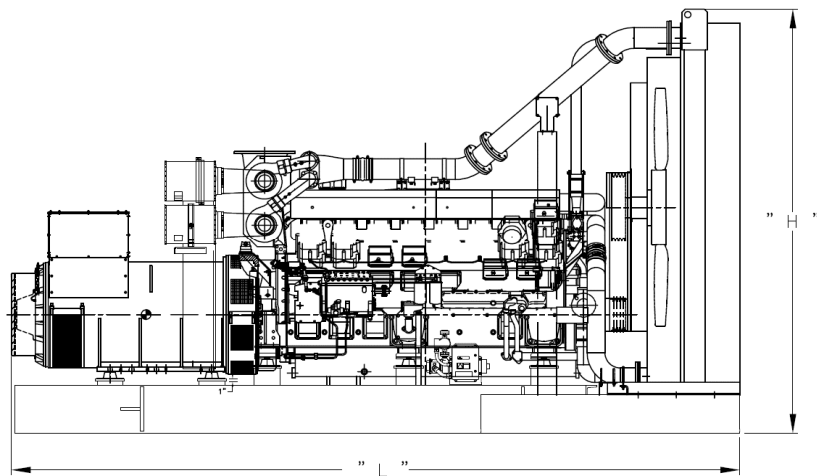
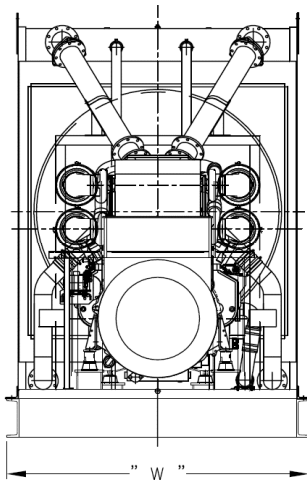

GENERATOR DATA *

L = LENGTH - inch (mm)	W = WIDTH - inch (mm)	H = HEIGHT - inch (mm)	DRY WEIGHT - lbs (kg)
180 (4572)	80 (2032)	96.0 (2438.4)	20892.4 (9475)

* All measurements are approximate and for estimation purposes only. Images are reference only.
 Any deviation can change dimensions.
 Materials and specifications subject to change without notice.



Simson Maxwell

Calgary | Edmonton | Nanaimo | Port Coquitlam | Prince George | Terrace | Ft. St. John

www.simson-maxwell.com | 800-374-6766

