

### 60Hz POWER RATINGS

Voltage AC	Phase	PF	Standby		Prime*	
			KW	A	Kw	A
120/240	1	1	182	758	165	688
120/208	3	0.8	183	635	166	577
277/480	3	0.8	184	276	167	251
347/600	3	0.8	184	222	167	201

\* Prime power rating for reference only.

## Overview of the SIMMAX series of Industrial Generator Sets

Simson-Maxwell generators are factory-built in facilities that utilize the latest technology, mechanical and electrical component assembly, production, and testing. Each model is the result of computer-aided design and modeling backed up by exhaustive prototype-testing. Our development technology results in a unique range of innovative designs for highly reliable generator sets backed-up by a comprehensive warranty covering all components.

## Standard Configuration of Industrial Sets

- Long-life, heavy-duty, 4-cycle, direct injection diesel engine from a world-renowned manufacturer for economy of operation and maximum reliability and durability. Capable of full-rated load acceptance in one step.
- Cooling: Radiator with belt driven pusher fan.
- Filtration: Heavy duty replaceable element air-cleaner.
- Alternator: Single bearing, 4-pole, rotating field, self-excited, self-ventilated, 12-wire re-connectable (6-wire dedicated for 600V), 60Hz brushless alternator with Class H insulation. Automatic voltage regulator (AVR) providing close voltage regulation.
- Arrangement: Open skid with engine and alternator units close coupled together and with seismic anti-vibration isolators mounted between the assembly and a heavy-duty steel base. Lifting lugs are provided as per application.
- Auto Start Control Panel: Digital auto-start microprocessor based control panel with remote start capability.
- Starting System: Electric starter motor, battery cables, battery and belt driven charging alternator.
- CSA certified and meets CSA C282 requirements.

# SIMMAX



## POWER GENERATION

## DIESEL PRODUCT LINE

**SVW180 T6-T3**

120/240/208/480/600 Volts  
60 Hz/1800 RPM | Standby/Prime

### ENGINE SPECIFICATION

Manufacturer	Volvo
Model	TAD752GE
EPA certified	Tier-3
Crank shaft speed: rpm	1800
Fuel type	Diesel
Injection	Direct
Aspiration	Turbocharged
Number of cylinder	6
Cylinder arrangement	Inline
Displacement: L	7.15
Bore: mm	108
Stroke: mm	130
Engine standby power: kW	196.0
Engine prime power: kW	178.0
Cooling	Water cooled
Governor	Electronic
Starting motor voltage	24V DC
Compression ration	18.0:1
Air cleaner type	Double stage with cyclone

### EXHAUST SYSTEM

Maximum engine exhaust temperature: °F (°C)	860	( 460 )
Exhaust gas flow: CFM (m3/hr)	1335.0	( 2268.2 )
Max. permissible back pressure: PSI (kPA)	1.016	( 7 )

### COOLING SYSTEM

Radiator cooling air flow: CFM (m3/hr)	12926	( 21962 )	@Max 40°C ambient temperature
Max. restriction of cooling air: in.w.g. (kPA)	0.684	( 0.2 )	
Engine combustion air flow: CFM (m3/hr)	449	( 763 )	
Total intake air requirement: CFM (m3/hr)	13375	( 22724.3 )	
Total coolant capacity: Litre	34		

### HEAT BALANCE

Heat at rejection to coolant: kW	129.0
Heat at rejection radiation from engine: kW	22.0
Heat at rejection to engine exhaust: kW	153.0

### LUBRICATION SYSTEM

Oil pan capacity: Litre	31.0
Oil pan capacity with filter: Litre	34.0
Oil cooler	Integrated full flow
Recommended lubricating oil grade	VDS3/VDS2
Oil consumption at full load: Litre/hr	0.05
Oil pressure: PSI (kPA)	58.1 ( 400 )

# SIMMAX



**POWER  
GENERATION**

## DIESEL PRODUCT LINE

**SVW180 T6-T3**

120/240/208/480/600 Volts  
60 Hz/1800 RPM | Standby/Prime

### ENGINE ELECTRICAL SYSTEM

Starting motor voltage	24V DC
Battery capacity	4D, 12V, 1000A
Cranking Amps minimum	400 A at +20 °C

### FUEL SYSTEM

Recommended fuel	DIN EN590
Fuel supply line, min. ID: mm	15.0
Fuel return line min. ID: mm	15.0
Fuel supply line max. restriction: kpa	35
Fuel pump type	Engine-driven
Fuel filter	Fuel filter 0.005mm Prefilter 0.010mm

### FUEL CONSUMPTION

	Standby Power		Prime Power
100% Load Standby: Litre/hr	52.0	100% Load Prime: Litre/hr	48.1
75% Load Standby: Litre/hr	41.7	75% Load Prime: Litre/hr	38.6
50% Load Standby: Litre/hr	32.3	50% Load Prime: Litre/hr	28.8
25% Load Standby: Litre/hr	20.3	25% Load Prime: Litre/hr	19.6

### ALTERNATOR SPECIFICATION

Alternator manufacturer	STAMFORD
Alternator model	HCI434
Voltage	120V - 480V, 600V
Alternator type	Four pole, Rotating field
Excitation system	Brushless, PMG (MX341)
Power factor	0.8
Number of leads	12 leads reconnectable (120V-480V-600V)
Stator pitch	2/3
Insulation	Class H
Windings - temperature rise / Ambient °C	125 / 40
Enclosure rating	IP23
Bearing	Single, Sealed
Amortisseur windings	Full
Voltage regulation - no load to full load with DSR AVR	± 1%
TIF	<50
Line harmonics	5% MAXIMUM
Alternator cooling air flow: CFM (m3/hr)	2100 ( 3568 )

### STANDARD FEATURES

• Radiator with pusher fan	• Standard fuel filter
• Medium-duty, Double stage with cyclone	• All rotating components protected with metal guards
• Heavy-duty engine start batteries with cables	• Operation and installation literature
• Emergency stop switch	• CSA certified
• Control Panel (See next page for details)	• Steel base for mounting on fuel tank/concrete surface

### OPTIONAL FEATURE: SUB-BASE FUEL TANK \*

Runtime	24 hour	48 hour	72 hour
Tank volume - US gal (L)	329.6 (1247.7)	659.2 (2495.3)	988.8 (3742.9)
Tank size: L x W x H - inch	112 x 45 x 19	112 x 45 x 34	135 x 45 x 40
Tank size: L x W x H - m	2.9 x 1.2 x 0.5	2.9 x 1.2 x 0.9	3.5 x 1.2 x 1

\* All measurements are approximate and for estimation purposes only. The tank dimensions may vary. For specific sizes, contact sales representative.

Rev: A

Date: 3/29/2018

## Control Systems Standard Features - Generator Digital Control Panel

### Standard Configuration of Control Systems

- Numerous control systems available, depending on customer requirements
- Automatic or manual start/stop
- Pre-lube function with timers
- Adjustable crank attempts
- Engine warm up/cooling functions
- Digital metering with alarms and shutdowns
- LCD display
- LED indicators
- In-built PLC function
- RS232 (optional RS485 or CAN) communication
- Data logging up to 350 events
- Password protection



## Key dimensions and Weights

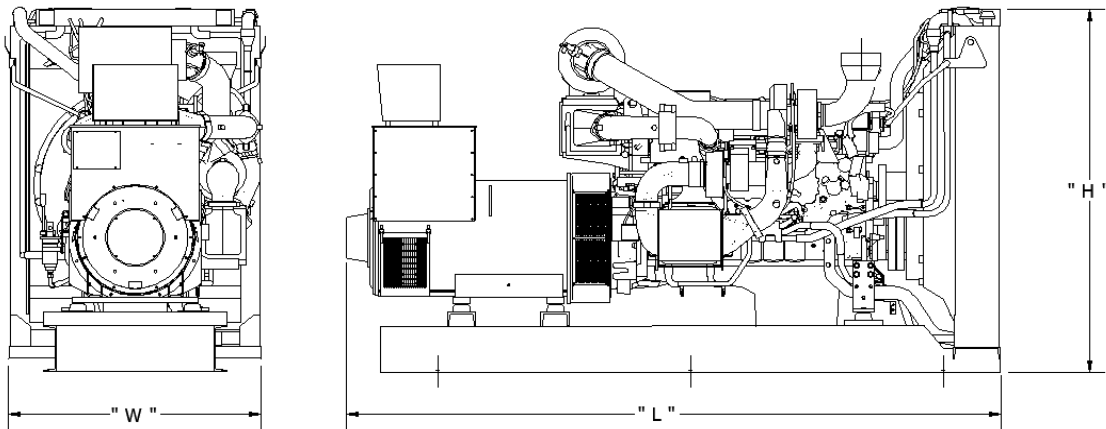

### GENERATOR DATA \*

L = LENGTH - inch (mm)	W = WIDTH - inch (mm)	H = HEIGHT - inch (mm)	DRY WEIGHT - lbs (kg)
111 ( 2819.4 )	44 ( 1117.6 )	62.0 ( 1574.8 )	4848.1 ( 2198.7 )

\* All measurements are approximate and for estimation purposes only. Images are reference only.  
Any deviation can change dimensions.  
Materials and specifications subject to change without notice.



Simson Maxwell

Calgary | Edmonton | Nanaimo | Port Coquitlam | Prince George | Terrace | Ft. St. John

www.simson-maxwell.com | 800-374-6766

